

# EWA/YQ64BA

01	Braze plate heat exchanger
02	Coil
03	Compressor
04	Expansion valve
05	Gas stopvalve
06	Liquid stopvalve
07	Switchbox hydromodule
08	Chilled water IN (G2 female shutoff valve)
09	Chilled water OUT (G2 female shutoff valve)
10	Water drain
11	Air purge
12	Leaving water temperature sensor
13	Entering water temperature sensor
14	Ambient temperature sensor
15	Refrigerant filler
16	Power supply intake (045)
17	Low voltage supply intake (029)
18	High voltage supply intake (029)
19	Lifting eye for sling
20	Main isolator switch
21	Flowswitch
22	Fan
23	Gas pipe sensor
24	Liquid pipe sensor
25	Water filter
26	Water safety valve (Optional)
27	Water pressure gauge (Optional)
28	Pump (Optional)
29	Expansion vessel (Optional)
30	Accumulator
31	Switchbox outdoor module
32	Main pcb hydro module
33	Demand pcb (Optional)
34	Low voltage terminal
35	High voltage terminal
36	Service panel outdoor module
37	Service panel hydro module
38	Service panel switchbox hydromodule
39	Water pressure port before brazed plate heat exchanger
40	Water pressure port after brazed plate heat exchanger

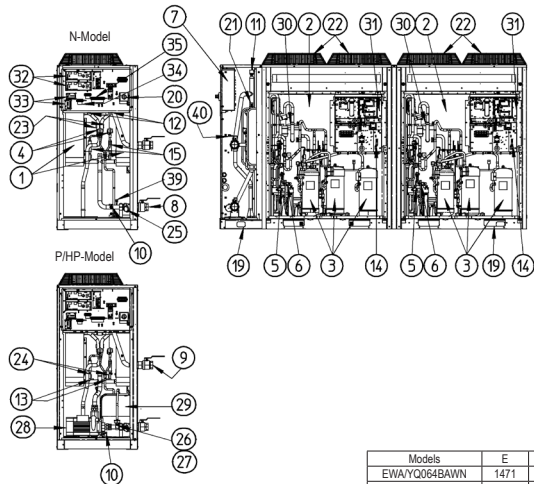

Models	E	F	G
EWA/YQ064BAWN	1471	388	590
EWA/YQ064BAWP	1430	394	578

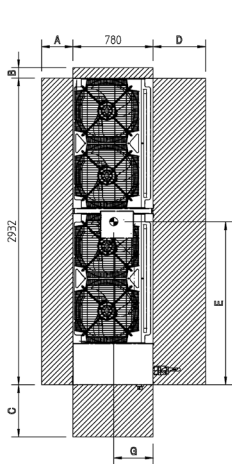
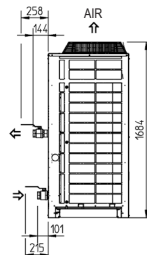
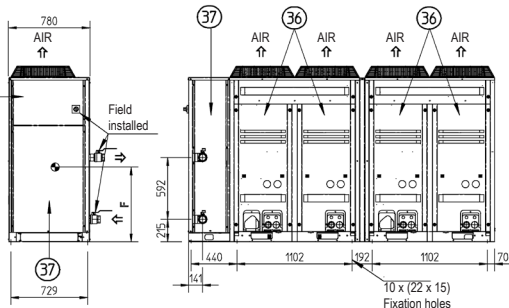
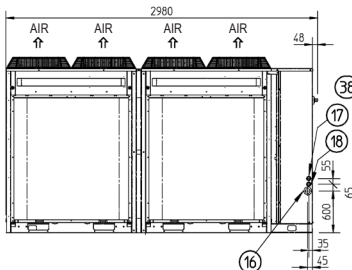

Legend:

- Required space around the unit for service and air intake
- Centre of gravity

## NOTES

	1	2
A	300	500
B	100	500
C	500	500
D	500	500

1= Distance from wall (or other unit) for regions without heavy snowfall.  
2= Distance from wall (or other unit) for regions with heavy snowfall.